

Falns 86 m3

Technical data

Length over buffers	14540 mm
Capacity	86 m3
Payload	63,5 t
Tare weight	26,5 t
Maximum axle load	22,5 t
Wheel diameter	920 mm
Maximum speed	120 Km/h
Min curve-radius single wag.	75 m
Status	RIV
Registration – NSA	AFER (Romania)
Gauge	UIC 505 – 1 fig. 6

Loading

Opening length	12800 mm
Opening width	2400 mm

Unloading

Opening length	2 x 5700 mm
Opening width	610 mm

Gravity, bilateral

Pneumatic system for opening / closing of the hopper doors

Données techniques

Longueur hors tout	14540 mm
Volume utile	86 m3
Charge utile maximum	63,5 t
Tare	26,5 t
Charge max. par essieu	22,5 t
Diamètre de roue	920 mm
Vitesse maximum	37 t
Rayon de courbure mini	75 m
Statut	RIV
Immatriculation - ANS	AFER (Roumanie)
Gabarit	UIC 505 – 1 fig.6

Chargement

Longueur d'ouverture	12800 mm
Largeur d'ouverture	2400 mm

Déchargement

Longueur d'ouverture	2 x 5700 mm
Largeur d'ouverture	610 mm

Gravité, bilatéral

Système pneumatique d'ouverture / fermeture des trappes

Coal car

Wagon charbon

Kohlewagen

Carro per carbone

Technische Daten

Länge über Puffer	14540 mm
Volumen	86 m3
Ladegewicht	63,5 t
Eigengewicht	26,5 t
Maximale Radsatzlast	22,5 t
Raddurchmesser	920 mm
Max. Geschwindigkeit	120 Km/h
Min. befahrbarer Kurvenradius	75 m
Statut	RIV
Immatriculation - NSB	AFER (Rumänien)
Begrenzungslinie	UIC 505 – 1 fig.6

Beladung

Öffnungslänge	12800 mm
Öffnungsbreite	2400 mm

Entladung

Öffnungslänge	2 x 5700 mm
Öffnungsbreite	610 mm

Schwerkraft, beidseitig

Pneumatische Klappenbetätigung

Dati tecnici

Lunghezza sopra respingenti	14540 mm
Capacità	86 m3
Carico utile	63,5 t
Tara	26,5 t
Carico massimo per sala	22,5 t
Diametro della ruota	920 mm
Velocità massima	120 Km/h
Raggio min. di curvatura/sing. carro	75 m
Stato	RIV
Immatricolazione - ANSF	AFER (Romania)
Scartamento	UIC 505 – 1 fig. 6

Caricamento

Lunghezza di apertura	12800 mm
Larghezza di apertura	2400 mm

Scarico

Lunghezza di apertura	2 x 5700 mm
Larghezza di apertura	610 mm

Gravità, bilateralmente

Sistema pneumatico per aprire / chiudere tramoggia

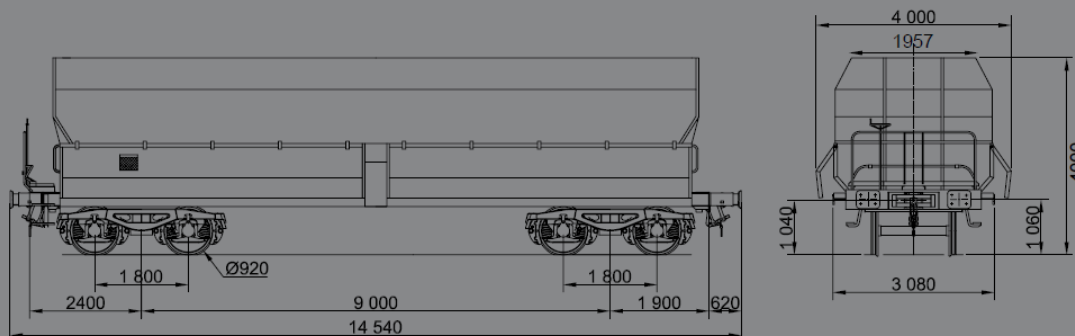

	A	B	C	D
S	28.0	46.0	56.0	63.5
I20	00.0			

Document non contractual
Non contractual document