

Falns 80 m3

Technical data

Length over buffers	14540 mm
Capacity	80 m3
Payload	64 t
Tare weight	26 t
Maximum axle load	22,5 t
Wheel diameter	920 mm
Maximum speed	120 Km/h
Min curve-radius single wag.	75 m
Status	RIV
Registration – NSA	AFER (Romania)
Gauge	UIC 505 – 1 fig. 6
Loading	
Opening length	12800 mm
Opening width	2400 mm
Unloading	
Opening length	2 x 5700 mm
Opening width	610 mm
Gravity, bilateral	
Pneumatic system for opening / closing of the hopper doors	

Données techniques

Longueur hors tout	14540 mm
Volume utile	80 m3
Charge utile maximum	64 t
Tare	26 t
Charge max. par essieu	22,5 t
Diamètre de roue	920 mm
Vitesse maximum	37 t
Rayon de courbure mini	75 m
Statut	RIV
Immatriculation - ANS	AFER (Roumanie)
Gabarit	UIC 505 – 1 fig.6
Chargement	
Longueur d'ouverture	12800 mm
Largeur d'ouverture	2400 mm
Déchargement	
Longueur d'ouverture	2 x 5700 mm
Largeur d'ouverture	610 mm
Gravité, bilateral	
Système pneumatique d'ouverture / fermeture des trappes	

Coal car Wagon charbon

Technische Daten

Länge über Puffer	14540 mm
Volumen	80 m3
Ladegewicht	64 t
Eigengewicht	26 t
Maximale Radsatzlast	22,5 t
Raddurchmesser	920 mm
Max. Geschwindigkeit	120 Km/h
Min. befahrbarer Kurvenradius	75 m
Statut	RIV
Immatriculation - NSB	AFER (Rumänien)
Begrenzungslinie	UIC 505 – 1 fig.6
Beladung	
Öffnungslänge	12800 mm
Öffnungsweite	2400 mm
Entladung	
Öffnungslänge	2 x 5700 mm
Öffnungsweite	610 mm
Schwerkraft, beidseitig	
Pneumatische Klappenbetätigung	

Dati tecnici

Lunghezza sopra respingenti	14540 mm
Capacità	80 m3
Carico utile massimo	64 t
Tara	26 t
Carico massimo per sala	22,5 t
Diametro della ruota	920 mm
Velocità massima	120 Km/h
Raggio min. di curvatura /sing. carro	75 m
Stato	RIV
Immatricolazione - ANSF	AFER (Romania)
Scartamento	UIC 505 – 1 fig. 6
Caricamento	
Lunghezza di apertura	12800 mm
Larghezza di apertura	2400 mm
Scarico	
Lunghezza di apertura	2 x 5700 mm
Larghezza di apertura	610 mm
Gravità, bilateralmente	
Sistema pneumatico per aprire / chiudere tramoggia	

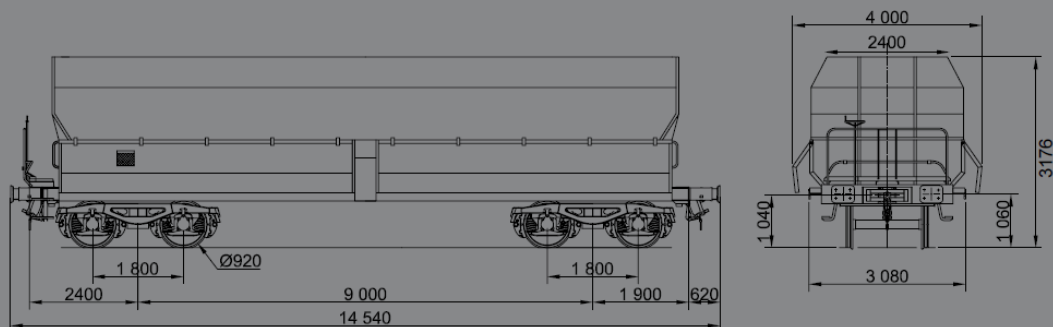

	A	B	C	D
S	28.0	46.0	56.0	64.0
I20	00.0			

Document non contractual
Non contractual document