

### 102t UK Aggregate Open Box

Aggregate Open Box  
Wagon tombereau

Offener Güterwagen  
Vagone tutto aperto

#### Technical data

Length over buffers	13 970 mm
Overall length	12 730 mm
Overall height	3 177 mm
Loading length	12 758 mm
Loading width	2 470 mm
Cubic Capacity	60m <sup>3</sup>
Tare weight	24.45 t
Payload ca.	77.15 t
Axle load	25.4 t
Minimum curve	70 m
Maximum speed	100 km/h

#### Technische Daten

Länge über Puffer	13 970 mm
Gesamtlänge	12 730 mm
Gesamthöhe	3 177 mm
Ladelänge	12 758 mm
Ladebreite	2 470 mm
Volumen	60m <sup>3</sup>
Eigengewicht	24.45 t
Lastgrenze	77.15 t
Radsatzlast	25.4 t
Min. befahrbarer Kurvenradius	70 m
Max. Geschwindigkeit	100 km/h

#### Données techniques

Longueur hors tout	13 970 mm
Longueur totale	12 730 mm
Hauteur totale	3 177 mm
Longueur utile	12 758 mm
Largeur utile	2 470 mm
Volume utile	60m <sup>3</sup>
Tare	24.45 t
Limite de charge	77.15 t
Limite de charge par essieu	25.4 t
Rayon de courbure minimum	35 m
Vitesse maximum	100 km/h

#### Dati tecnici

Lunghezza sopra respingenti	13 970 mm
Lunghezza complessiva	12 730 mm
Altezza complessiva	3 177 mm
Lunghezza di carico	12 758 mm
Larghezza di carico	2 470 mm
Capacità	60m <sup>3</sup>
Tara	24.45 t
Carico utile	77.15 t
Carico utile per sala	25.4 t
Raggio min. di curvatura	70 m
Velocità massima	100 km/h

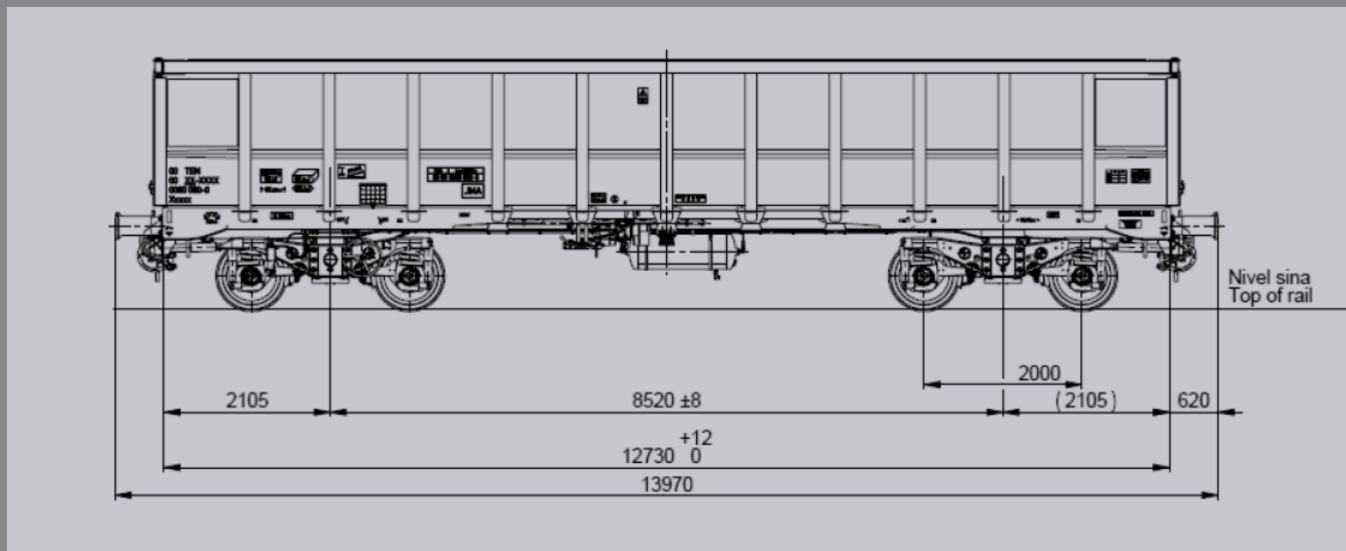

**Manufacturer: Greenbrier.**

**The wagons are UK registered.**

**The wagons have been designed primarily for the conveyance of aggregates, sand and non-corrosive minerals.**